

DEVIL'S SLIDE OPENS POSSIBILITIES

by Kevin Harper,
California Department of Transportation

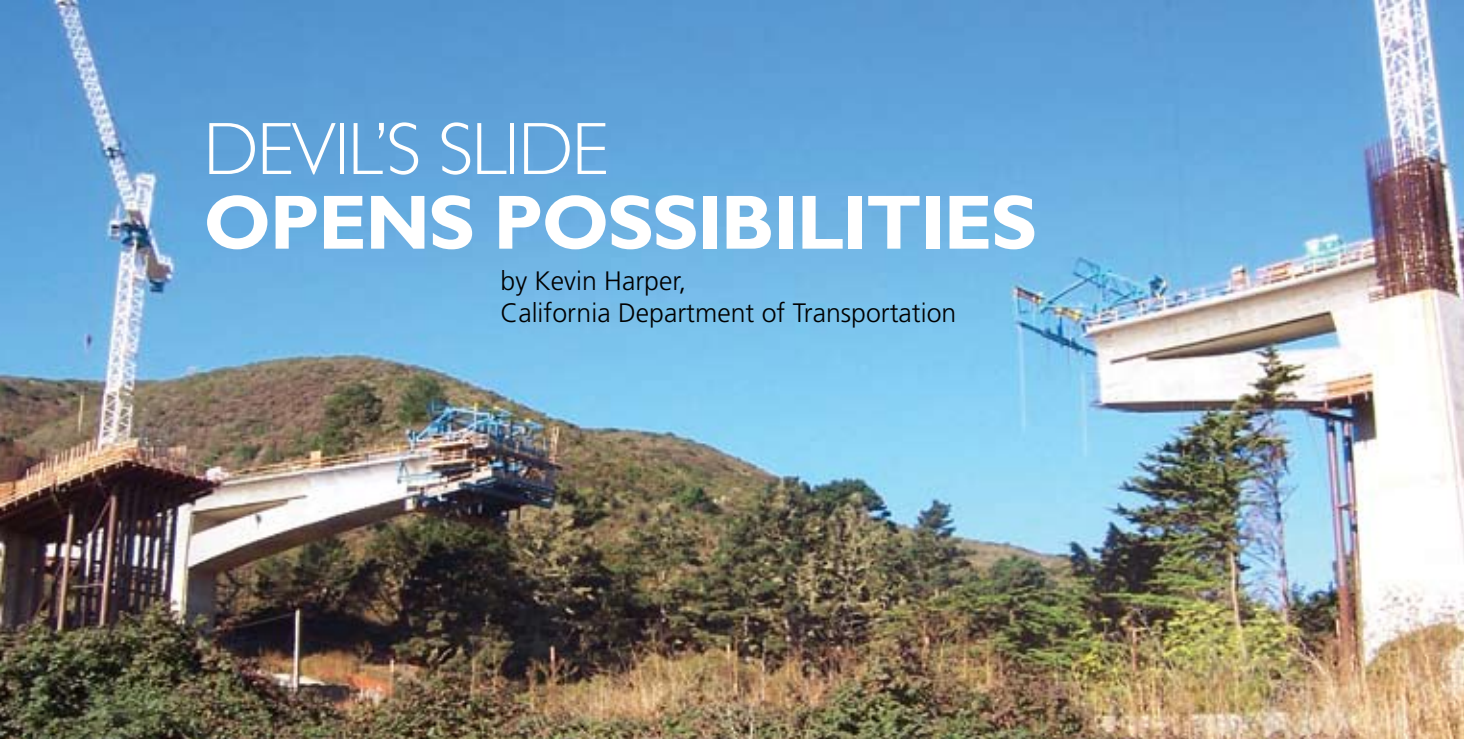

The segmental cantilevers of the west bridge (southbound) extend out over the environmentally sensitive valley where even foot traffic is prohibited.

California engineers and contractors are closely watching this segmental, cast-in-place concrete bridge, which may create new approaches in the state.

California bridge designers and contractors have not built many segmental bridges, owing to their expertise with other types of construction. But a bridge project now underway along the Pacific Coast Highway in northern California, and another following shortly behind, may open the door to more such projects, particularly in areas with difficult terrain or with requirements for large falsework openings.

The project, which consists of two side-by-side curved bridges, is located about 18 miles south of San Francisco between Pacifica and Montara and will connect Highway 1 to the north portal of two tunnels running through San Pedro Mountain. Each three-span bridge is approximately 1000 ft long and 29 ft wide. Two sets of twin piers on each side of the valley support 445-ft-long, cast-in-place concrete box girder main spans. Because of the structures' curved design and the shape of the valley, the

end spans for the west structure are significantly longer than the end spans on the east bridge. The west bridge end spans are 281 ft and 251 ft while the east bridge spans are 230 ft and 225 ft. The concrete has a specified compressive strength of 6100 psi.

Balanced Cantilever Approach Used

Caltrans engineers designed the bridges to be constructed by the balanced-cantilever method without falsework under the cantilevers. However, the contractor is using a balanced-cantilever approach that incorporates falsework for the end spans. This method still eliminates the need for falsework in the main span, where it would interfere with the environmental constraints. But it retains falsework for the end spans, which is the method most familiar to contractors in the state.

profile

DEVIL'S SLIDE BRIDGES / PACIFICA, CALIFORNIA

ENGINEER: California Department of Transportation, Sacramento, Calif.

PRIME CONTRACTOR: Disney Construction Inc., San Mateo, Calif.

CONTRACTOR'S ENGINEER: Nutt, Redfield & Valentine (NRV), Sacramento, Calif.

CONCRETE SUPPLIER: Central Concrete Supply Co. Inc., South San Francisco, Calif.

FORM TRAVELER AND POST TENSIONING SUPPLIER: Schwager Davis Inc., San Jose, Calif.

TRAVELER FORMWORK: DOKA, Little Ferry, N.J.



The designers' bridge model shows the design for the completed Devil's Slide tunnel project. The bridges connect existing Route 1 to the North Portals of the tunnels by passing over the environmentally sensitive coastal wetlands in the valley below.

The bridges were designed according to project specific design criteria that incorporate portions of the Caltrans LFD Bridge Design Specifications (based on the AASHTO Standard Specifications 16th edition), 1999 AASHTO Guide Specifications for Segmental Concrete Bridges, and the Caltrans Seismic Design Criteria. TDV RM2006 software was used by Caltrans' engineers to analyze for construction loading, live load, and seismic response. SAP2000 and Wframe were used for the pushover analysis.

The center span's balanced cantilevered method eliminates the need for falsework at the bridge's center, where it would interfere with the environment.

The successful contractor has no previous experience with segmental bridge construction. To some extent, that would be true for many contractors in the state. They have become proficient in using falsework, to heights of 150 ft and greater, and conditions haven't necessitated finding other approaches. So there have been few designs that used segmental construction. But because of the environmental impact in this case, cantilevered, segmental construction provided the best option.

The bridges are part of an emergency project to relocate a portion of the scenic Highway 1 inland away from a large landslide area known as the Devil's Slide. The goal is to realign the highway through San Pedro Mountain with a double-bore, 4200-ft-long tunnel and approaches outside the influence of the active landslide. The bridges will join a host of scenic bridges located along this famous route, most notably the Bixby Creek Arch Bridge to the south and the Golden Gate Bridge to the north.

The bridges pass over a valley and are about 130 ft above the valley floor at their highest point. To ensure no personnel, equipment or falsework entered the wetland boundary, a main span of 135.8 m (445 ft) was needed to span the environmentally sensitive area. The alignment required a total bridge length of 296 m (972 ft) with a portion of the bridges on a tight, horizontal curve with a radius of 260 m (853 ft).

The bifurcated pier table is first constructed on falsework on each side of the piers. For the end spans, the three 15-m (49.2-ft)-long segments are cast on falsework. The nine main span segments with lengths of 4.1 m or 5.0 m (13.5 ft or 16.4 ft) are constructed using a pair of form travelers.

Temporary concrete ballast blocks are used on the end-span segments to keep them from lifting off the falsework, as three main-span segments are progressively cast after each back-span segment. A closure is then cast

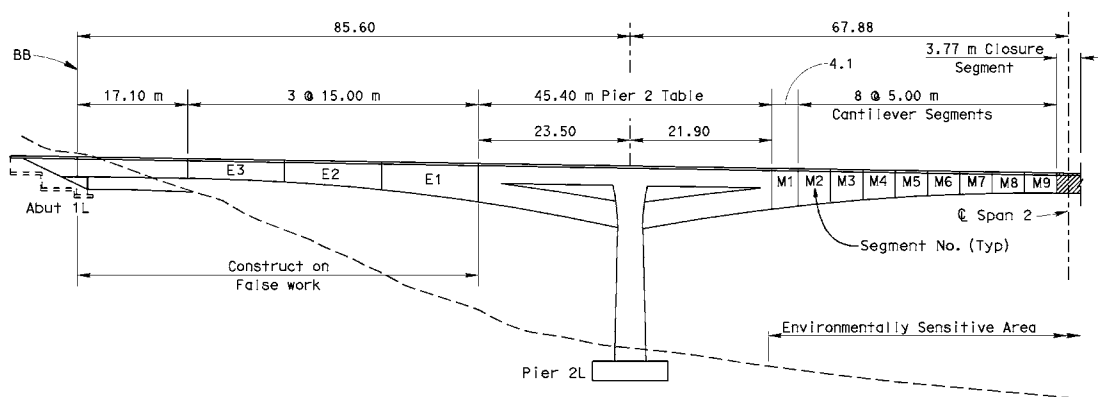

The bridges are being constructed by a balanced-cantilever approach that incorporates falsework in the end spans and form travelers in the main spans over the environmentally sensitive area.

CAST-IN-PLACE CONCRETE SEGMENTAL BOX GIRDER / CALIFORNIA DEPARTMENT OF TRANSPORTATION, OWNER

REINFORCING STEEL SUPPLIER: Pacific Coast Rebar, San Diego, Calif.

DRILLING & SHORING SUBCONTRACTOR: Drill Tech Drilling & Shoring, Antioch, Calif.

BRIDGE DESCRIPTION: Two side-by-side cast-in-place segmental concrete bridges connecting to tunnels being bored through San Pedro Mountain

STRUCTURAL COMPONENTS: Cast-in-place concrete box girders with a main span of 445 ft; west bridge end spans of 281 ft and 251 ft; east bridge end spans of 230 ft and 225 ft

BRIDGE CONSTRUCTION COST: \$33.07 million

Aesthetics were given a top priority on every section of the bridge.

at midspan. When the west bridge segments are completed, the travelers will be moved to the east bridge to start the process all over again.

The bridge construction is expected to be completed in 2008. The 30-ft-wide tunnel excavations connecting to the bridge at their north portals, are to be completed in 2011.

Second Project Underway

A similar project has begun construction approximately 200 miles to the north at the South Fork Eel River Bridge. It is part of an emergency project to relocate about 1.5 miles of Route 101 away from an active landslide known as Confusion Hill. Awarded to MCM Construction, it also will provide California bridge contractors with more experience in segmental bridge construction.



Form travelers are used to construct the main span cast-in-place segments over the environmentally sensitive valley below.

The project relocates the highway from the east side of the river to the west side via two bridges. The north bridge features a prestressed cast-in-place, slant leg, box girder bridge that is about 150 ft above the river and is being constructed on falsework. The larger southern bridge is 275 ft above the river, requiring a different construction method. It is a segmental cast-in-place box-girder constructed by the balanced cantilever method similar to the Devil's Slide project except a traveler also will be used on the end span side of the cantilever instead of falsework. The tall bridge piers are hollow, with highly confined corner elements. That project is scheduled for completion in 2009 and will be featured in a future edition of *ASPIRE*.™

Three additional large, balanced-cantilever segmental bridges are being designed by Caltrans for later construction. The Antlers Bridge on I-5 over Lake Shasta, the Lake Britton Bridge on State Route 89, located in northern California, and the Pitkins Curve Bridge on State Route 1 in Monterey County will all use this approach due to the unique constraints of their locations.

The competition among local contractors, and the awarding of the Devil's Slide and South Fork Eel River bridge contracts to local firms, bodes well for the continuation of this approach for more California bridges. As contractors become familiar with it, more will enter the bidding processes, and their bids will become even more competitive.



While the main span segments are cast using a form traveler, the end span segments, which are outside the environmentally sensitive area, are cast on falsework. The abutment retaining walls mimic the shape of the rounded exterior girders to give the impression that the bridges continue on into the hillside.

With local companies experienced in falsework becoming willing to embrace the segmental construction method, attitudes within the local construction industry are likely to change in favor of this method. That will be especially true for project locations with difficult terrain or with requirements for large falsework openings. Such a change should help create more cost-efficient bridges, as well as meet the environmental challenges that certainly will continue to grow.

Kevin Harper is Bridge Engineer with the California Department of Transportation, Sacramento, California.

For more information on this or other projects, visit www.aspirebridge.org.

Bridge Aesthetics Were Crucial

Because of its location, bridge aesthetics were critical to the design, and public input reinforced that need. A standard monolithic structure was not considered adequate mitigation at the site. Given the restraints of the site and the design criteria, the segmental, cast-in-place, box girder bridge was selected as the best approach.

Aesthetics were given a top priority on every section of the bridge. Near the piers, the variable-depth superstructure bifurcates vertically into two distinct elements, with an upper box girder and a lower box girder strut element that gives the bridges a graceful, shallow arched appearance. The bridges also incorporate special aesthetic treatment on the abutments and retaining walls, as well as including specially designed "see through" concrete barriers and custom bicycle rails.

Environmental Protection

The bridges pass over a valley at Shamrock Ranch, which contains a pond and wetlands that are home to the endangered red-legged frog. During construction, the wetland area has been fenced off to protect the environmentally sensitive area; thereby necessitating the use of cantilevering.

This project's success bodes well for the continuation of this approach for more California bridges.

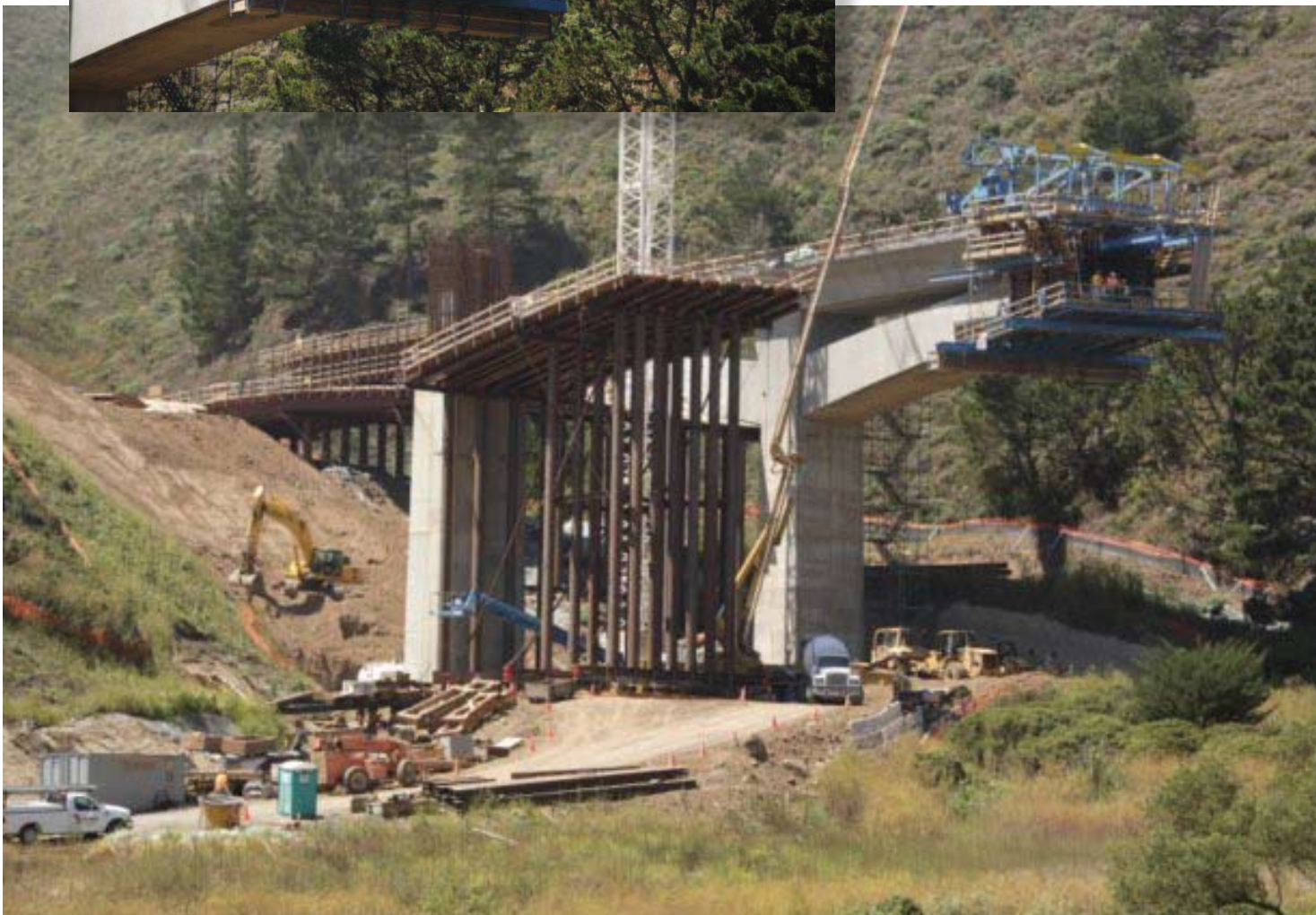

Aesthetics were given top priority on every element of the bridge. Within the pier tables, the superstructure bifurcates vertically into two distinct elements, with an upper box girder and a lower box-girder strut element that give the bridges a graceful, shallow arched appearance.

